

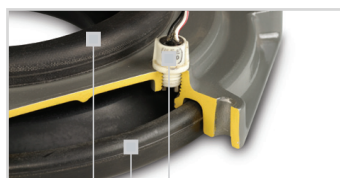

**YANMAR**

MARINE DIESEL ENGINES

## Yanmar Sailerdrive SD25 Series

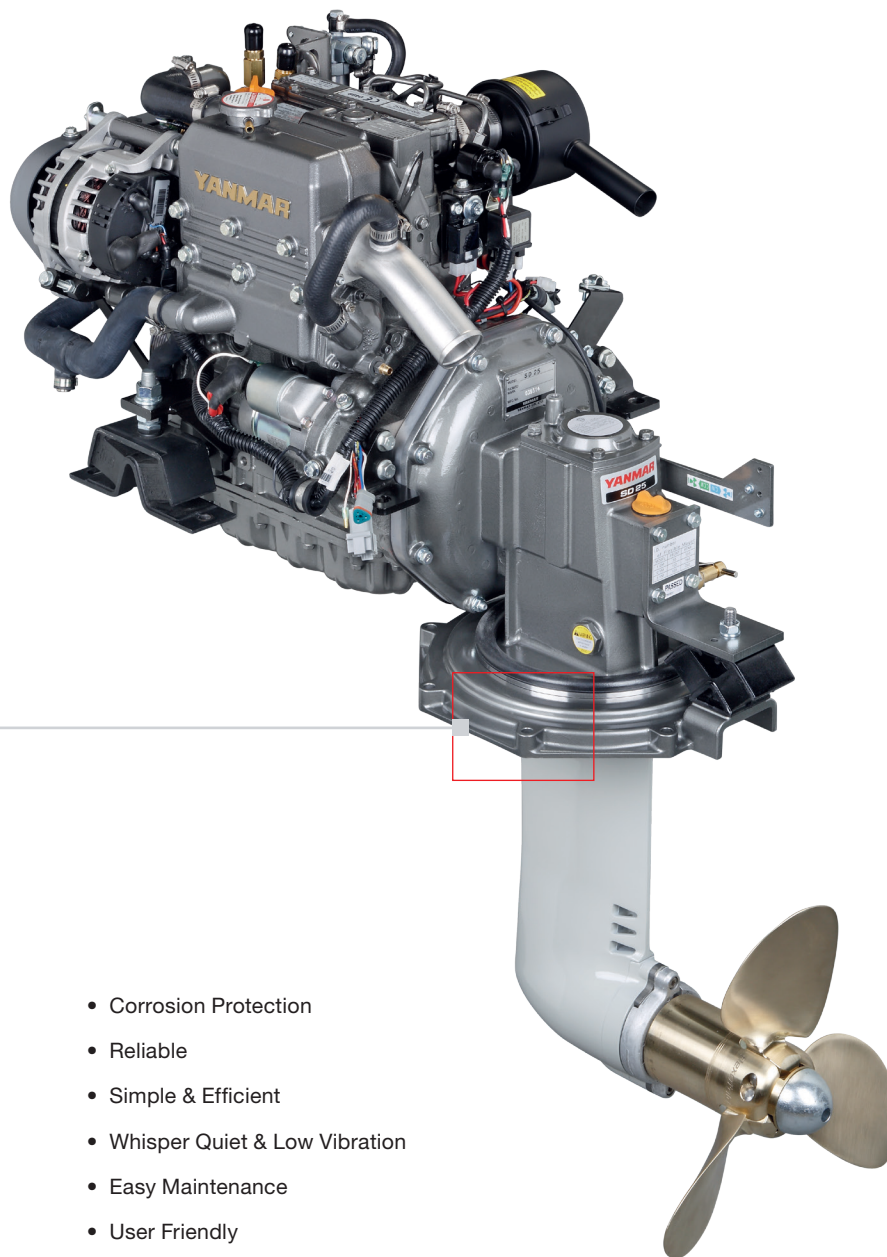

Aqua Sensor  
Outer Seal  
Inner Seal

- Corrosion Protection
- Reliable
- Simple & Efficient
- Whisper Quiet & Low Vibration
- Easy Maintenance
- User Friendly
- Extra Protection

Yanmar Sailerdrive Type	SD25
Reduction gear system	Constant mesh gear with dog clutch
Reduction ratio [fwd/asn]	2.64/2.64
Direction of rotation [propeller shaft - fwd]	Counterclockwise viewed from flywheel side
Dry weight Sailerdrive	30 kg [66 lbs]

[www.yanmar.eu](http://www.yanmar.eu)

EN\_DS2500\_1214



**YANMAR**

Engine Model	1GM10C x SD25	2YM15C x SD25	3YM20C x SD25	3YM30AEC x SD25
Configuration	4-stroke, vertical, water-cooled diesel engine	4-stroke, vertical, water-cooled diesel engine	4-stroke, vertical, water-cooled diesel engine	4-stroke, vertical, water-cooled diesel engine
Maximum output at crankshaft	* 6.6 kW@3600 rpm [9 mhp@3600 rpm]	* 10.0 kW@3600 rpm [13.6 mhp@3600 rpm]	* 15.3 kW@3600 rpm [21 mhp@3600 rpm]	* 21.3 kW@3200 rpm [29.1 mhp@3200 rpm]
Displacement	0.318 ltr [19.41 cu in]	0.57 ltr [34.7 cu in]	0.854 ltr [52.1 cu in]	1.115 ltr [68 cu in]
Bore x stroke	75 mm x 72 mm [2.95 in x 2.83 in]	70 mm x 74 mm [2.8 in x 2.9 in]	70 mm x 74 mm [2.8 in x 2.9 in]	80 mm x 84 mm [3.1 in x 3.3 in]
Cylinders	1	2	3	3
Combustion system	Indirect injection	Indirect injection	Indirect injection	Indirect injection
Aspiration	Natural aspiration	Natural aspiration	Natural aspiration	Natural aspiration
Starting system	Electric starting with manual combination	Electric starting 12V - 1.4 kW	Electric starting 12V - 1.4 kW	Electric starting 12V - 1.4 kW
Alternator	12V - 40A	12V - 125A	12V - 125A	12V - 125A
Cooling system	Fresh water cooling by centrifugal water pump and rubber impeller sea water pump	Fresh water cooling by centrifugal water pump and rubber impeller sea water pump	Fresh water cooling by centrifugal water pump and rubber impeller sea water pump	Fresh water cooling by centrifugal water pump and rubber impeller sea water pump
Lubrication system	Enclosed, forced lubricating system	Enclosed, forced lubricating system	Enclosed, forced lubricating system	Enclosed, forced lubricating system
Lubrication oil for Saildrive	API CC and SAE 10W30	API GL4 or GL5 and SAE 80W90 or SAE 90	API GL4 or GL5 and SAE 80W90 or SAE 90	API GL4 or GL5 and SAE 80W90 or SAE 90
Direction of rotation [propeller]	Counterclockwise viewed from flywheel side	Counterclockwise viewed from flywheel side	Counterclockwise viewed from flywheel side	Counterclockwise viewed from flywheel side
Dry weight with Saildrive	104 kg [229 lbs]	134 kg [295 lbs]	144 kg [317 lbs]	157 kg [346 lbs]
Environmental	EU: RCD BSO II EMC	EU: RCD BSO II EMC US: EPA Tier3	EU: RCD BSO II EMC US: EPA Tier3	EU: RCD BSO II EMC US: EPA Tier3
Engine mounting	Rubber type flexible mounts	Rubber type flexible mounts	Rubber type flexible mounts	Rubber type flexible mounts

**NOTE:**

Fuel condition: Density at 15°C = 0.84 g/cm<sup>3</sup>; 1kW = 1.3596 mhp = 1.3410 HP

\* Fuel temperature 40°C at the inlet of the fuel injection pump [ISO 8665:2006]

Technical data is according to ISO 8665: 2006/3046-1

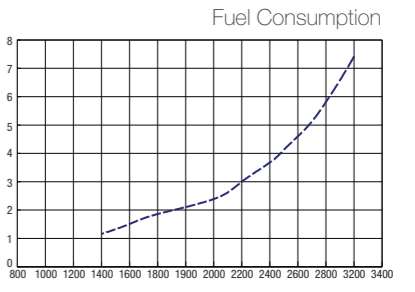
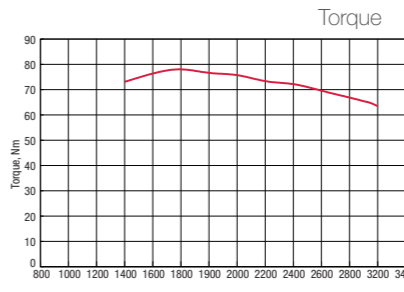
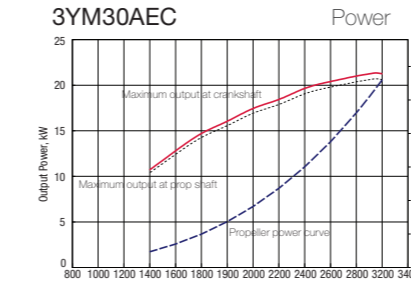
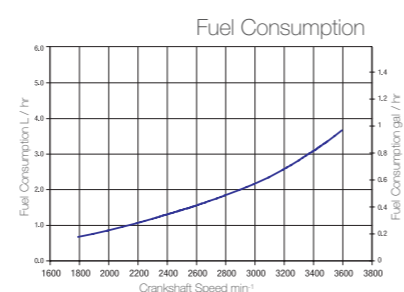
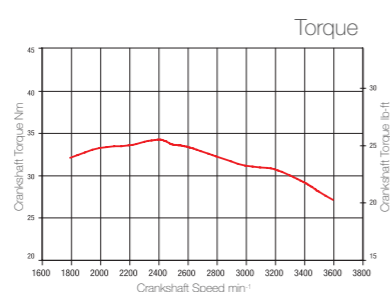
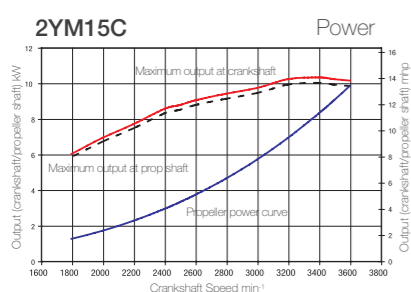
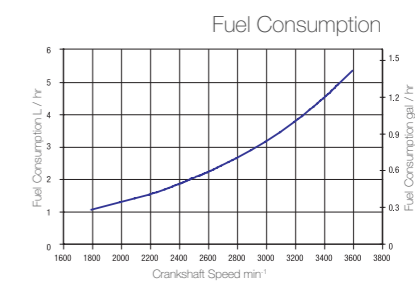
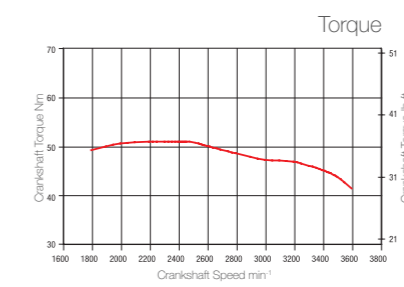
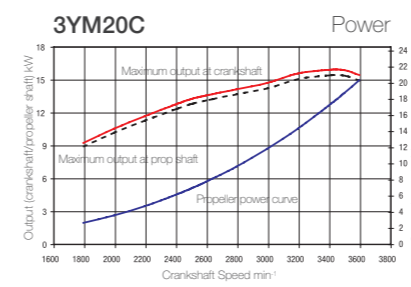
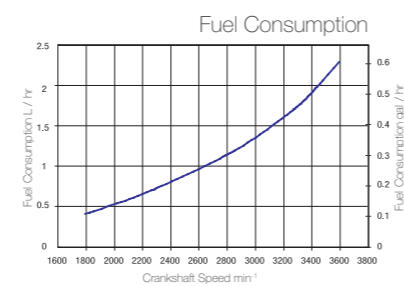
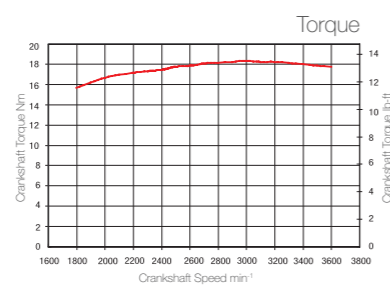
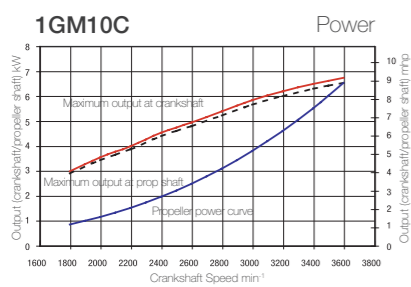



**YANMAR**

1GM10C

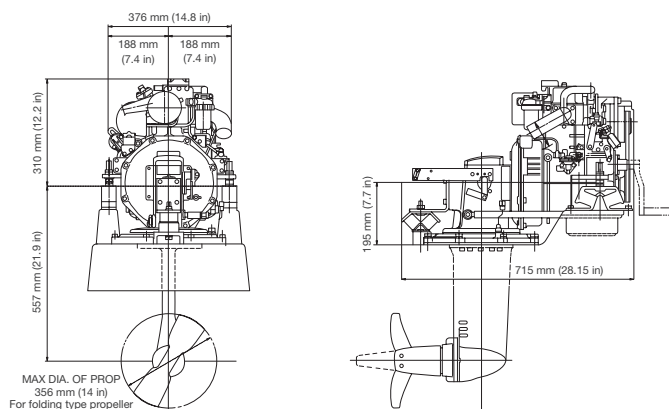

2YM15C

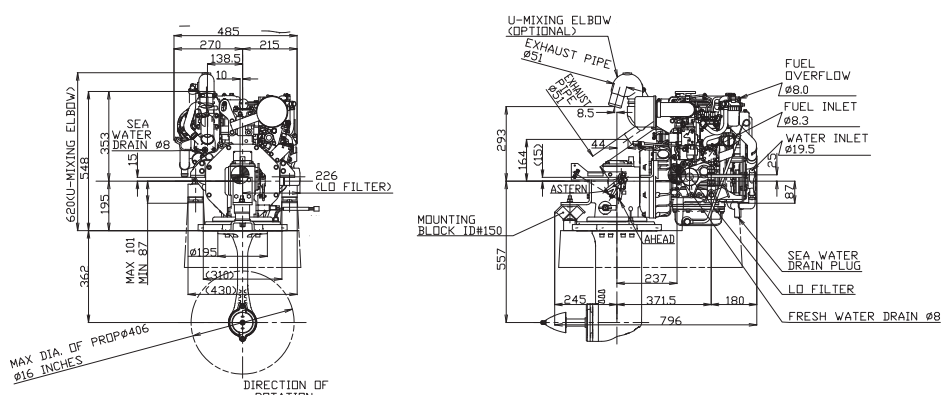

3YM20C

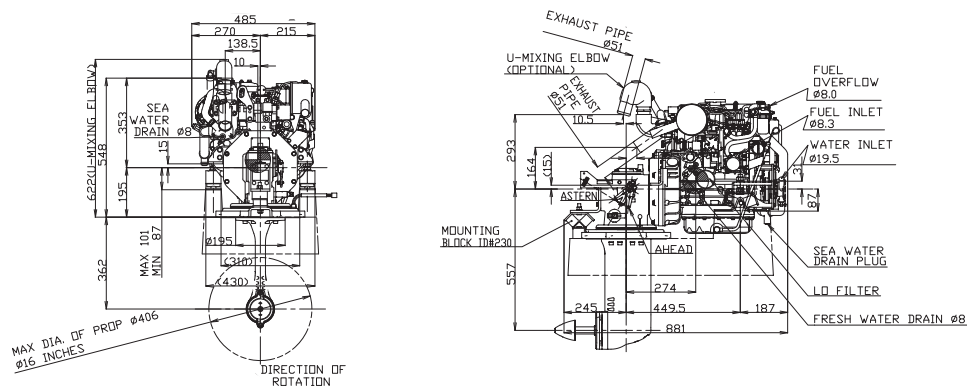

3YM30AEC

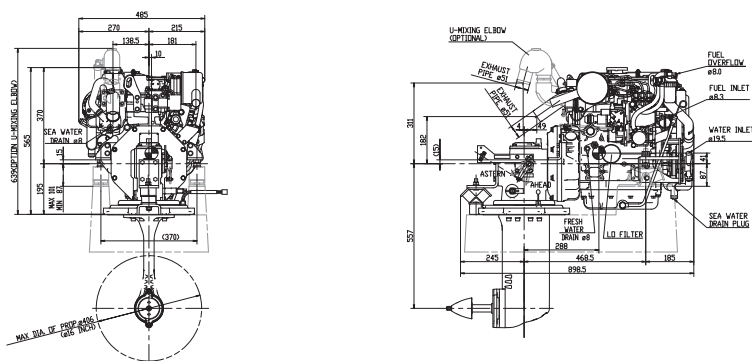

NOTE: All data subject to change without notice. Text and illustrations are not binding.